

Single Scale Bulk Fill

*Your solution for fast, accurate
filling of loose items*



Key Benefits:

- Reduction in labor and repetitive stress injuries
- More accurate fill weights vs. manual operation
- “Bulk” fills at first for speed and switches to trickle fill for accuracy

Key Features:

- Industrial Design – Design and built with three shift operations and 304 stainless steel framing
- Industry Standard Control – Controlled by industry standard PLC controls as opposed to proprietary weighing boards
- Space Saver Footprint – Product is fed at a 6’ elevation eliminating the need for vertical lift or long incline conveyors.

About The Single Scale Bulk Fill Case Packer

The Single Scale Bulk Fill Case Packers is perfect for applications requiring fast, accurate filling of loose items such as cookies, candy bars, chicken nuggets, IQF vegetables, cheese, flavor packets, condiments, etc. The machine fills at first for speed and switches to trickle fill for accuracy. The single scale bulk filler uses the industry proven CSW series weighing platform and the industry standard PLC control.

Packaging Distributors, Inc.

www.pdimachinery.com

P (254) 848-8123

E rjf@pdimachinery.com



1

2

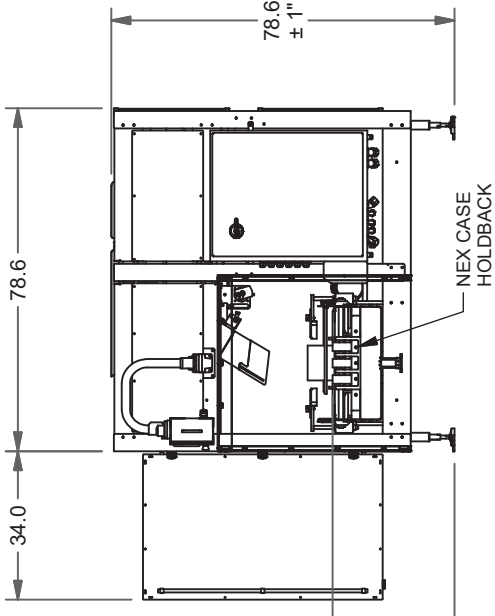
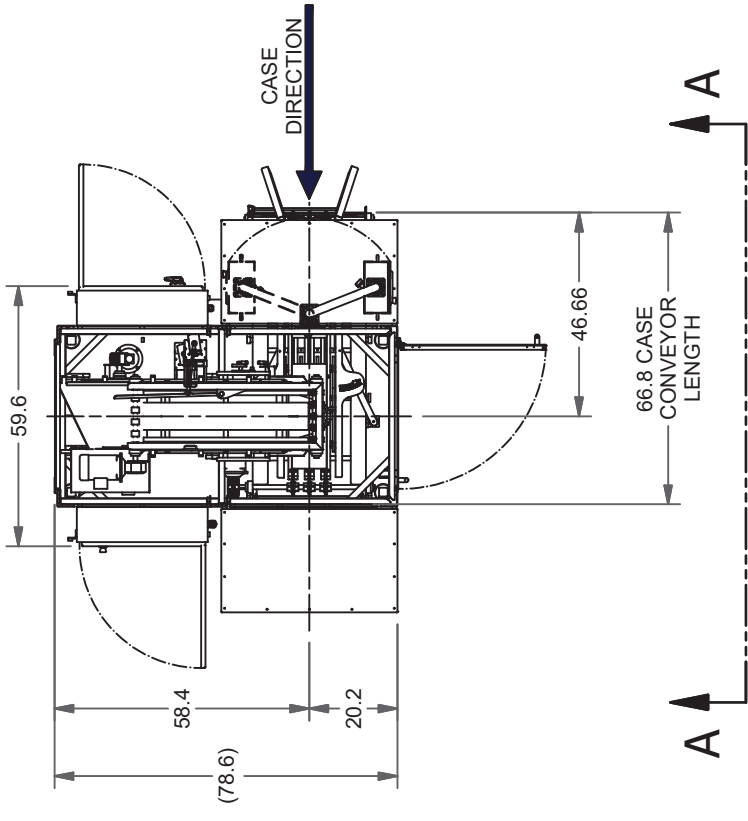

END VIEW
B-B

28.0
± 1"
CONV.
HEIGHT

NOTE:
RIGHT HAND MODEL SHOWN
LEFT HAND MODEL AVAILABLE

ELECTRICAL REQUIREMENTS: 480 VAC 3-PHASE FUSED AT 10 AMPS
AIR REQUIREMENTS: 80 PSI, < 3 SCFM

MAXIMUM CASE DIMENSION (INCHES) 24"L x 16"W x 14"T
MINIMUM CASE DIMENSION (INCHES) 12"L x 8"W x 6"T
(Case height + top flaps not to exceed 20"T max)

TOLERANCE UNLESS NOTED		PACKAGING DISTRIBUTORS, INC.	
DECIMAL	PROJECT	SCALE	DRAWN BY S. FIRMIN
X.XX = ±0.010			DESIGNER R.FALLAS
X.XXX = ±0.003	TITLE		SHEET NO.
FRACTIONAL	SINGLE SCALE BULK PACKER (Right Hand)		1 of 1
X = ± 1	DATE	DRAWING NUMBER	REV BY ECN
X = ± 32	9/21/2017	DPS1009RH	
ANGULAR	REV DESCRIPTION		
±0.5			

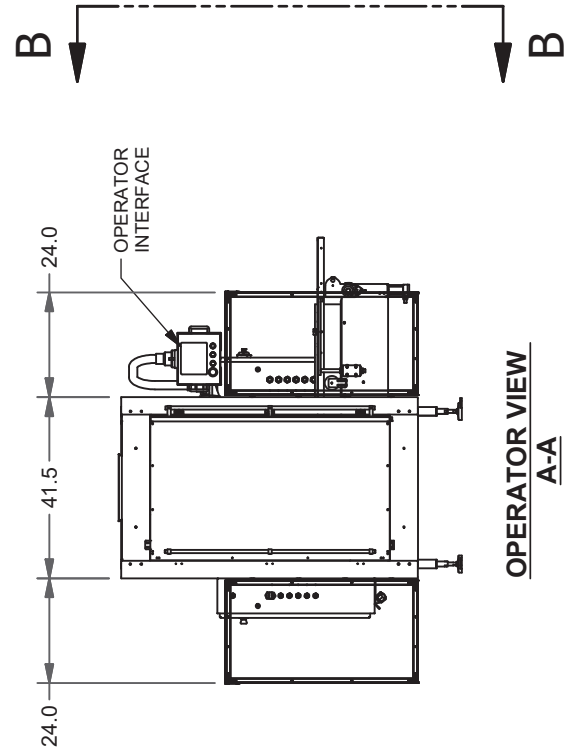

OPERATOR VIEW
A-A

B

B



A

A

1

2

